

Instruction Manual

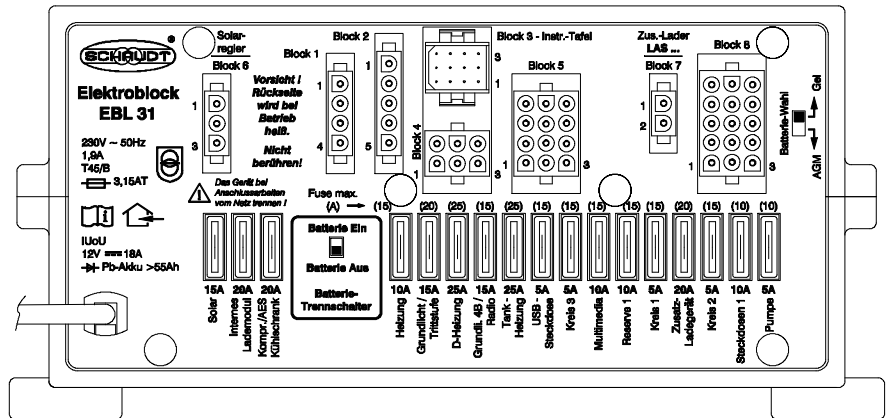

Elektroblock EBL 31 EBL 31 with OVP

Contents

1	Safety information	2
1.1	Meaning of safety symbols	2
1.2	General safety information	2
2	Introduction	3
3	Operation	3
3.1	Starting up the system	3
3.2	Changing the battery	4
3.3	Operating faults	5
3.4	Closing down the system	6
4	Application and functions in detail	7
4.1	Battery functions	8
4.2	Additional functions	9
5	Technical details	9
5.1	Mechanical details	9
5.2	Electrical details	9
5.3	Environmental parameters	10
6	Maintenance	11
	Appendix	12

1 Safety information

1.1 Meaning of safety symbols



▲ DANGER!

Failure to comply with this sign may result in danger to life or physical condition.



▲ WARNING!

Failure to comply with this sign may result in injury.



▲ ATTENTION!

Failure to comply with the sign may result in damage to equipment or other connected loads.

1.2 General safety instructions

The design of the device is state-of-the-art and complies with approved safety regulations. Failure to observe the safety instructions may nonetheless lead to injury or damage to the device.

Only use the device when it is in perfect technical condition.

Any faults affecting the safety of individuals or the proper functioning of the device must be repaired immediately by specialists.



▲ DANGER!

230V units carrying mains voltage.

Risk of fatal injury due to electric shock or fire:

- Do not carry out maintenance or repair work on the device
- If cables or the device housing are damaged, no longer use the device and isolate it from the power supply
- Ensure that no liquids enter the device



▲ WARNING!

Hot components

Burns:

- Only change blown fuses when the device is fully de-energised
- Blown fuses may only be replaced once the cause of the fault is known and has been rectified
- Never bypass or repair fuses
- Only use original fuses rated as specified on the device
- Device parts can become hot during operation. Do not touch them.
- Never store heat sensitive objects close to the device (e.g. temperature sensitive clothes if the device has been installed in a wardrobe)

2 Introduction

This instruction manual contains important information on safe operation of the device. Make sure you read and follow the safety instructions provided.

The operating instructions should always be kept in the vehicle. All safety information must be passed on to other users.

3 Operation

The electroblock is operated solely via the IT ... / LT ... control and switch panel connected. .

For daily use, no operation is needed on the EBL 31 electroblock (exception: the battery cut-off switch should be disabled when the vehicle is not in use, see Section 3.4).

One-off adjustments only have to be made if the battery type is changed (lead-gel or AGM), during initial start-up or when retrofitting accessories (see Section 3.2 and the installation instructions for the EBL 31).

Overvoltage protection OVP

The EBL 31 with OVP electroblock is suitable for all applications in which the risk of overvoltage is particularly high. For example, lightning strikes on the national grid, generator operation and poor electronic installations at camping sites.

For this, an overvoltage protection unit is fitted in the electroblock between the mains connection and the charge module. In the event of over or under-voltage, this overvoltage protector isolates the electroblock from the 230V supply within just a few milliseconds. It remains cut off until the main voltage has normal values again.

3.1 Starting up the system



▲ ATTENTION!

Incorrect electroblock settings.

Damage to connected devices. Therefore prior to starting:

- Ensure the leisure area battery is connected.
- Ensure that the battery selector switch (Fig. 4, Pos. 10) is set to the correct position for the battery installed.
- ▶ Move the battery cut-off switch (see Fig. 4, Pos. 12) to the "Battery ON" position.
- ▶ Use the main 12V switch (see instruction manual of relevant control and switch panel) to switch on/off all the consumers and the control and switch panel.

The following outputs are exceptions:

- Basic light/step
- Heater
- Frost protection valve
- AES/compressor refrigerator
- D-Heater
- Basic light 4B

These outputs are not disabled from the main switch of the IT ... / LT ... control and display panel.

Please refer to the operating instructions of the IT ... / LT ... control and switch panel for further information. .

3.2 Changing the battery



▲ ATTENTION!

Use of incorrect battery types or incorrectly rated batteries.
Damage to the battery or devices connected to the electroblock:

- Batteries may only be changed by qualified personnel.
- Follow the battery manufacturer's instructions.
- Only use the electroblock to connect to 12V power supplies with rechargeable 6-cell lead-gel or AGM batteries. Do not use any unsuitable battery types.



Changing the battery

▲ Normally only batteries of the same type and capacity should be used, i.e. the same as those installed by the manufacturer.

- ▶ Electrically isolate the battery from the electroblock. For this, switch off the battery separation switch on the EBL 31 electroblock (refer also to Section 3.4).
- ▶ Replace the battery.
- ▶ After changing the battery, recheck which type of battery has been inserted.



▲ DANGER!

Incorrect setting of the battery selector switch.
Risk of explosion due to build up of explosive gases:

- Move the battery selector switch to the correct position.
- ▶ Disconnect the electroblock from the mains before adjusting the battery selector switch.

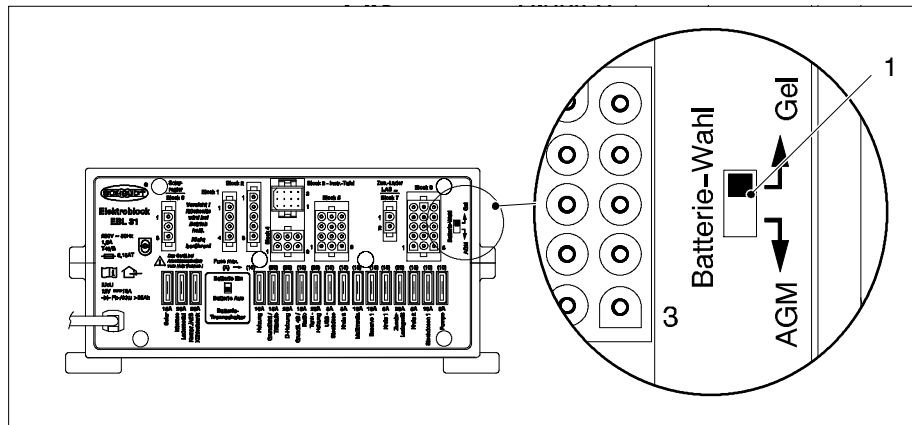

Fig. 1 Battery selector switch

- ▶ Move the battery selector switch (Fig. 1, Pos. 1) to the correct position using a thin object (e.g. a ballpoint pen):
 - Lead-gel battery: Move the battery selector switch to "Gel".
 - AGM battery: Move the battery selector switch to "AGM".

Starting up the system

- ▶ Start up the system as described in Section 3.1.

3.3 Faults

Flat vehicle fuses A flat battery or defective fuse is the cause of most faults in the power supply system.

Discharged battery - start motor If the battery is discharged, consumers can always be powered by starting the engine of the base vehicle.

Please contact our customer service address if you cannot rectify the fault using the following table.

If this is not possible, e.g. if you are abroad, you can have the electrobloc repaired at a specialist workshop. In this case, you must ensure that the warranty is not invalidated by incorrect repairs being carried out. Schaudt GmbH will not accept any liability for damage resulting from such repairs.

Fault	Possible cause	Remedy
Leisure area battery is not charged during 230V operation (battery voltage constantly below 13.3 V)	No mains voltage	Switch on the automatic circuit breaker in the vehicle; check the mains voltage
	Too many consumers are switched on	Switch off any consumers not required
	Defective electrobloc	Contact customer service
Living area battery is overcharged during 230V operation (battery voltage constantly above 14.5 V)	Defective electrobloc	Contact customer service
Starter battery is not charged during 230V operation (battery voltage constantly below 13.0 V)	No mains voltage	Switch on the automatic circuit breaker in the vehicle; check the mains voltage
	Too many consumers are switched on	Switch off any consumers not required
	Defective electrobloc	Contact customer service
Leisure battery is not charged during mobile operation (battery voltage below 13.0 V)	Defective alternator	Have the alternator checked
	No voltage on D+ input	Have the fuse and cabling checked
	Defective electrobloc	Contact customer service
The leisure battery is overcharged during mobile operation (battery voltage permanently above 14.3 V)	Defective alternator	Have the alternator checked
The refrigerator does not work during mobile operation	No power supply to the refrigerator	Have the fuse (20A of supply; possibly 2A of the D+ signal) and wiring checked
	Defective electrobloc	Contact customer service
	Defective refrigerator	Have the refrigerator checked
Solar charging does not work	Solar charge regulator not plugged in	Plug in solar charge regulator
	Defective fuse or cabling	Have the fuse and cabling checked
	Solar charge regulator defective	Have solar charge regulator checked

Fault	Possible cause	Remedy
12V supply does not work in the leisure area	12V main switch for the living area battery is switched off	12V main switch for the living area battery must be switched on
	Not all plugs/fuses are plugged into the electroblock	Pug all plugs and fuses (correct ratings) into the electroblock
	Defective fuse or cabling	Have the fuse and cabling checked
	Defective electroblock	Contact customer service



- ▲ The charging current is reduced automatically if the device becomes too hot due to excessive ambient temperature or lack of ventilation. Always prevent the device from overheating nevertheless.
- ▲ If the automatic shutdown mechanism of the battery monitor is triggered, fully charge the living area battery.

3.4 Closing down the system

The battery is isolated by switching off the battery cut-off switch.



▲ ATTENTION!

Total discharge.

Damage to the leisure area battery:

- Fully charge the living area battery before and after closing down the system. (Connect vehicle to the mains with an 80Ah battery at least 12 hours and with a 160Ah battery at least 24 hours).

Closing down

Disconnect the living area battery from the 12V power supply if the motorhome is not used for a longer period (during the winter for example).

- ▶ Fully charge the living area battery before closing down the system.
- ▶ Switch off the main switch on the IT ... / LT ... control and display panel.
- ▶ Move the battery cut-off switch (see Fig. 4, Pos. 12) to the "Battery OFF" position. The following connections are isolated from the living area battery:
 - All 12V consumers
 - Frost protection valve
 - Operator and control panel

The living area battery is then protected against total discharge. This only applies if the battery is intact. Follow the battery manufacturer's instructions.



- ▲ If the living area battery is isolated from the electroblock with the battery cut-off, the frost protection valve of the combination heater opens. A loss of water is possible (see the operating instructions for the combination heater).

4 Application and functions in detail

The EBL 31 electroblock is the central power supply unit for all 12V consumers in the vehicle's electrical system. It is usually located in a cupboard or storage area and is accessible from the front in order to change fuses.

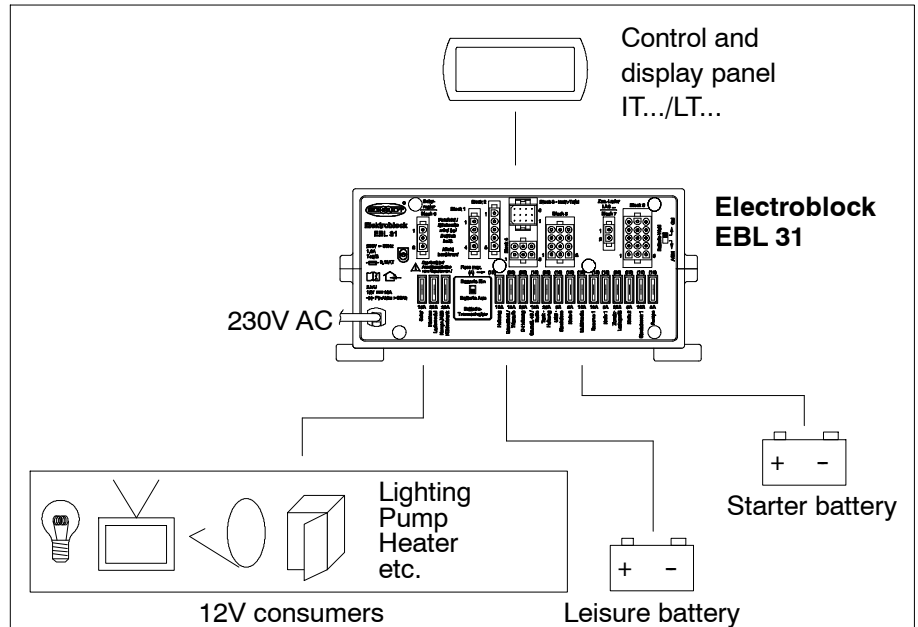

Fig. 2 On-board power supply system

Modules The EBL 31 electroblock contains:

- a charge module for charging all batteries connected
- the complete 12V distribution system
- fuses for the 12V circuits
- a battery monitoring module
- control and monitoring functions

System devices An IT ... or LT ... control and switch panel must be connected for operation. These devices control the electrical functions in the vehicle's living area, including accessories.

There is also an option to connect an additional charger and a solar loading regulator.

Flat vehicle fuses protect the various circuits. The D+ output is an exception.

Protective circuits of the charging module

- Excess temperature
- Overload
- Short circuit

Mains connection 230V AC \pm 10%, 47 to 63 Hz sinusoidal, protection class I

Current-carrying capacity 12V outputs may be loaded with max. 90% of the rated current of the respective fuse (also see front panel).

4.1 Battery functions

Suitable batteries 6-cell lead-gel or AGM batteries, 55 Ah and above

Battery charging whilst moving Simultaneous charging of the starter battery and the living area battery via the alternator, parallel connection of the batteries via a cut-off relay

Battery charging via solar charge regulator Maximum permitted charge current 14 A, fused with 15 A (for leisure area battery), simultaneous charging of the starter battery

Battery isolation The battery is isolated with the battery cut-off switch.

This prevents the living area battery from slowly discharging due to closed circuit current while the vehicle is not in use.

Battery selector switch The switching option provided by the battery selector switch ensures optimum charging of the battery types, lead-gel and AGM, for mains supply.

Automatic disconnecter The battery monitor compares the current of the living area battery with a reference current. As soon as the battery current drops below 10.5V, all 12V consumers are switched off via main switch relays 1 and 2.

Only the frost protection valve continues to be powered.

The automatic disconnecter is not triggered by short-term low voltage (shorter than 2 seconds), caused by high current when switching on consumers. If an overload or an insufficiently charged living area battery causes the voltage to fall so low that the automatic disconnecter is triggered, any non-essential consumers should be switched off.

If need be, the 12V supply can begin operation for a short time. For this, switch on the 12V main switch on the control and switch panel.

However, if the battery current remains below 11.0V, the 12V supply can not be switched on again. Fully charge the living area battery as soon as possible. For more information, see the description of "battery voltages".

4.2 Additional functions

Automatic switch function for AES/compressor refrigerator	This relay supplies the AES/compressor refrigerator with power from the starter battery when the vehicle engine is running and the D+ connection is live. An AES refrigerator is powered by the living area battery when the vehicle engine is not running.
Mains charging starter battery	This feature provides an automatic max. 6 A float charge for the starter battery when the 230V mains is connected to the electrobloc.
Overvoltage protection for the EBL 31 with OVP	The electrobloc is isolated from the mains within 10ms in the event of a voltage greater than 265 V ~ eff. The electrobloc switches itself back on again by itself after the mains voltage has attained the normal value.

5 Technical details

5.1 Mechanical details

Dimensions	130 x 275 x 170 (H x W x D in mm), including attachment feet
Weight	2.0 kg
Casing	PA (polyamide), gentian blue (RAL 5010)
Front	Aluminium, powder coated, light grey (RAL 7035)

5.2 Electrical details

Mains connection	230V AC $\pm 10\%$, 47 - 63 Hz sinusoidal, protection class I	
Current consumption	1.9 A	
Suitable batteries	6-cell lead-gel or AGM batteries, 55 Ah and above	
Standby current from leisure battery	Dependent on the control panel: approx. 5 - 20 mA, plus consumption of controller electronics of refrigerator	
	Conditions for the measurement:	
	<ul style="list-style-type: none"> ● approx. 10 minutes after disconnection from the mains ● 12.6 V battery voltage ● Battery alarm OFF ● Battery cut-off switch ON ● Lighting for operator and control panel OFF ● All consumers switched off ● 12V main switch off 	
D+ loading	Loading of D+ output of the alternator by the electrobloc approx. 0.5 mA without current consumption on D+ point	
Current-carrying capacity	12V outputs	A maximum of 90% of the nominal current of the relevant fuse may be drawn.
	Frost protection valve output	max. 0.1 A
	D+ point	1 A for fusing D+ input with 2 A

Battery charging via mains connector

Leisure battery

Battery selector switch setting	lead-gel	AGM
Charging curve	IUoU	IUoU
Final charge voltage	14,4 V / 16 h	14,7 V / 4 h
Charge current	18 A	18 A
Voltage for float charge	13,7 V with automatic switchover	13,7 V with automatic switchover

Battery charging of the starter battery

Starter battery

Charging current float charge max. 6 A
 Charging voltage typ. $U_{Wbat} - 0.2 V$

IUoU curve

New charge cycle for battery voltage < 13.7 V
 Switchover to main charging with approx. 5 seconds delay

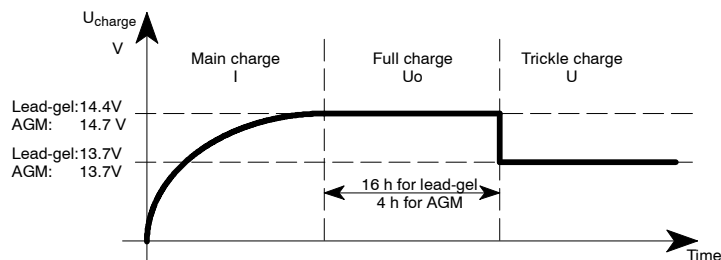

Fig. 3 Charging voltage curve with electroblock EBL 31

- I Main charge with maximum 18 A charging current, electronically limited, up to final charging voltage. Start of charge also for completely discharged batteries.
- Uo Automatic switchover to full charge with constant 14.4 V (lead-gel) or 14.7 V (AGM). The duration of the full charge phase is based on the battery type and is set on the device.
- U Automatic changeover to compensation charge with constant 13.7 V. In the compensation charge phase, the voltage at the output of the charging module is constant.

Start of a new charging cycle by switching over to main charge, if the battery voltage falls below 13.7 V for more than 5 seconds when loaded. Start of charge also for completely discharged batteries. The internal charge module can also be operated without leisure battery.

Interrupting voltage for EBL 31 with OVP

Overvoltage: Approx. 265 V ~ eff.
 This values applies for distortion-free sinusoidal voltage.

5.3 Environmental parameters

Operating temperature -20 °C to +45 °C

Storage temperature -20 °C to +70 °C

Humidity Operation in dry environment only

CE CE mark

6 Maintenance

The EBL 31 electroblock requires no maintenance.

Cleaning Clean the electroblock with a soft, slightly damp cloth and mild detergent. Never use spirit, thinners or similar substances. Do not allow liquids to enter the electroblock.

© No part of this manual may be reproduced, translated or copied without express written permission.

Appendix

A EC Declaration of Conformity

Schaudt GmbH hereby confirms that the design of EBL 31 electroblock complies with the following relevant regulations:

The original EC declaration of conformity is available for reference at any time.

Manufacturer Schaudt GmbH, Elektrotechnik & Apparatebau

Address Planckstraße 8
88677 Markdorf
Germany

B Special fittings/accessories

Panel Schaudt IT ... / LT ... control and display panel (required for operation)

Additional charger Schaudt battery charger LAS ... with max. 18 A charge current, including suitable connection cable (MNL).

Solar charge regulator Schaudt Solar charge regulator type LR ... for solar modules with a total current of 14A with 3-pole connection plug and connection cable

C Customer service

Customer service Schaudt GmbH, Elektrotechnik & Apparatebau
Planckstraße 8
88677 Markdorf, Germany

Phone: +49 7544 9577-16

Email: kundendienst@schaudt-gmbh.de

Web: www.schaudt-gmbh.de

Send in device Returning a faulty device:

- ▶ Complete and enclose the fault report, see Appendix D.
- ▶ Send it to the addressee (free delivery).

D Fault report

In the event of damage, please fill in the fault report and send it with the faulty device to the manufacturer.

Device type: _____
Item no.: _____
Vehicle: Manufacturer: _____
Model: _____
Own installation? Yes No
Upgrade? Yes No

Following fault has occurred (please tick):

- Electrical consumers do not work - which?
(please specify below)
- Switching on and off not possible
- Persistent fault
- Intermittent fault/loose contact

Other comments:

E Layout

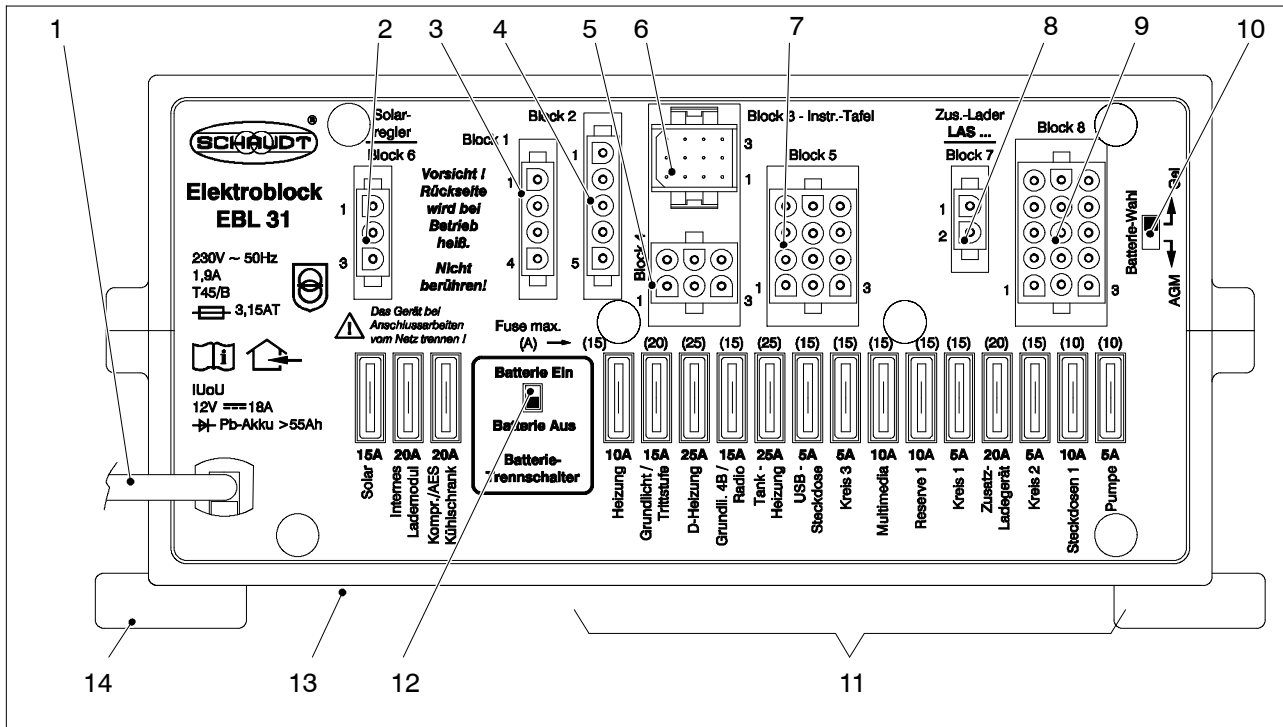

Fig. 4 Layout of the EBL 31 electroblok (front)

- | | |
|--|---|
| 1 Mains cable with WAGO plug connector | 8 Connection block, additional charger |
| 2 Connection block, solar regulator | 9 Connection block sockets 1, pump, circuits 1 to 3, Multimedia, spare 1, |
| 3 Connection block, refrigerator | 10 Lead-gel / AGM battery changeover switch |
| 4 Connection block, refrigerator supply D+, battery sensor/control lines | 11 Flat vehicle fuses |
| 5 Connection block, frost protection valve, heating and basic light/steps | 12 Battery cut-off switch |
| 6 IT ... / LT ... control and display panel connector | 13 Housing |
| 7 Connection block basic light 4B/radio, D heating, tank heating, USB port | 14 Assembly flaps |

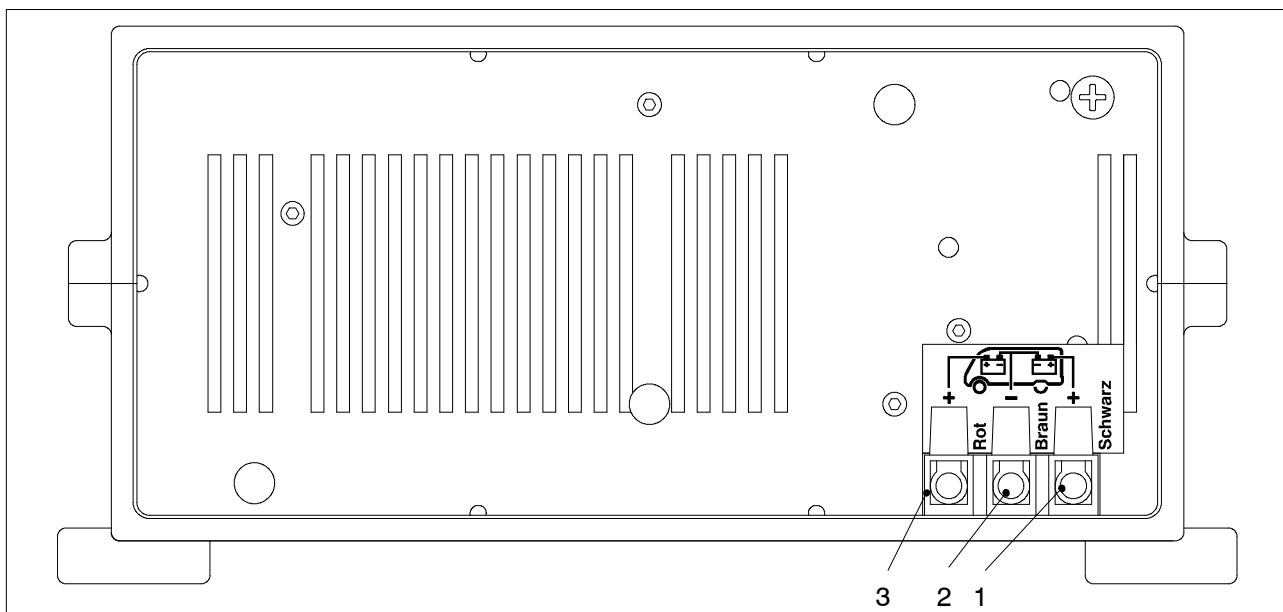
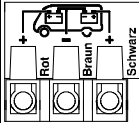

Fig. 5 Layout of the EBL 31 electroblok (rear)

- | | |
|-----------------------------------|-------------------------------|
| 1 Connection, living area battery | 3 Connection, starter battery |
| 2 Earth connector | |

F Connector assignment

Block	Pin	Signal	Use	Fuse	Colour code	Comment
5	9	+	Basic light 4B/radio	15 A (max. 15 A)	Blue (blue)	
	12	-				
	1	+	D heater	25 A (max. 25 A)	White (white)	
	4	+				
	5	-				
	10	-				
	2	+	Sockets 2	25 A (max. 25 A)	White (white)	
	3	+				
	7	-				
	8	-	USB port	5 A (max. 15 A)	beige (blue)	
6	+					
11	-					
6	3	WB	Solar charging, living area battery	15 A	blue	
	2	SB	Solar charging, starter battery	-	-	
	1	-	Negative, solar charger	-	-	
4	4	+	Frost protection valve	PTC 250 mA	-	
	1	+	Heater	10 A (max. 15 A)	Red (blue)	
	5	-				
	2	+	Basic light	15 A (max. 20 A)	Blue (yellow)	
	3	+	Step			
6	-	Basic light/step				
7	2	+	Auxiliary charger	20 A (max. 20 A)	Yellow (yellow)	
	1	-				
Screw-type terminal, rear		+ Red	Positive, starter battery	50 A	Red	External fuse (maxi fuse)
		- Brown	Leisure battery negative	-		The negative terminal of the leisure area battery must be connected externally to the negative terminal of the starter battery
		+ Black	Positive, living area battery	50 A	Red	External fuse (maxi fuse)
3	6		Mains indicator			
	4		Shunt battery	Polyswitch 2.5 A	-	Internal
	1		Shunt consumer	Polyswitch 2.5 A	-	Internal
	9		12V ON			
	12		12V OFF			
	5		12V indicator	Polyswitch 2.5 A	-	Internal
	2		Negative leisure area bat. sensor			
	11		+ Leisure battery sensor			
	8		+ Starter battery	Polyswitch 2.5 A	-	Internal
	3		Not assigned			
2	5	+	Leisure battery sensor	2 A	Grey	External fuse
	2	-		-	-	
	1	+	Starter battery for refrigerator	20 A	Yellow	External fuse
	3	D+	Engine running	2 A	Grey	External fuse
1	4	-	Starter battery for refrigerator			
	4	+	Compressor/AES refrigerator	-	-	
	1	+	Absorber refrigerator	-	-	
	2	D+	Output D+	-	-	
8	3	-	Refrigerator			
	6	+	Sockets 1	10 A (max. 10 A)	Red (red)	
	12	-				
	9	+	Pump	5 A (max. 10 A)	beige (red)	
	14	-				
	2	+	Circuit 1	5 A (max. 15 A)	beige (blue)	
	8	-				
	3	+	Circuit 2	5 A (max. 15 A)	beige (blue)	
	10	-				
	7	+	Circuit 3	5 A (max. 15 A)	beige (blue)	
	13	-				
	4	+	Multimedia	10 A (max. 15 A)	Red (blue)	
	11	-				
	1	+	Spare 1	10 A (max. 15 A)	Red (blue)	
	5	-				
15	n.a.	-				

G Block diagram/wiring diagram

